



**ACME MANUFACTURING CORP.**

6532 TOWER LANE, CLAREMORE, OK. 74019

ENGINEERED PRODUCTS BY CRAFTSMEN

## Self-Flashing Curb Custom With Wood Nailer Type SFCWN

### STANDARD FEATURES

Constructed of 18 ga. galv. steel with continuous welded seams and integral base plate for water tightness and extra strength.

Wide base flashing to insure adequate bond to roofing surface for water tight seal to roof.

Lined with 1½" fiberglass fire proof sound attenuating insulation.

2 x 2 wood nailer secured to top ledge of curb.

Custom sizes to meet any dimensional requirement or roof opening.

### OPTIONS

- Constructed of .063" aluminum.
- Interior metal liner.
- Standard heights of 12, 14, 16, 18, 20, 24", or any special height.
- Damper shelf – standard or custom size opening.
- Back draft damper.
- Damper motor, 120, 240, or 480 vac.
- Security bars.
- Treated wood nailer.
- Protective or decorative coatings.
- Heavy-gage construction.

PROJECT	
LOCATION	
ARCHITECT	
ENGINEER	
CONTRACTOR	
SUBMITTED BY	
DATE	PO#

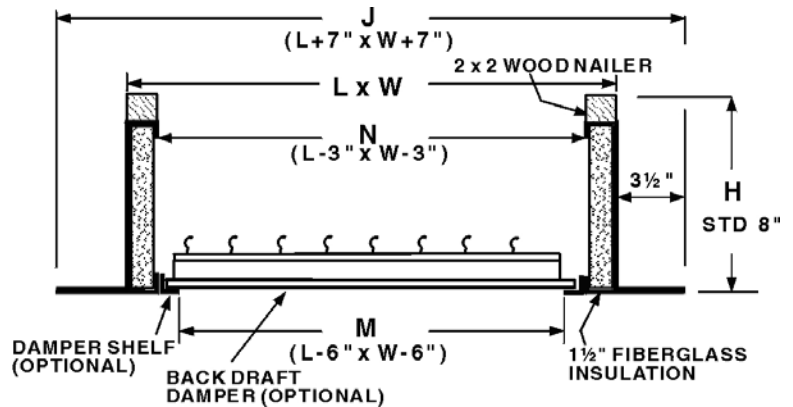
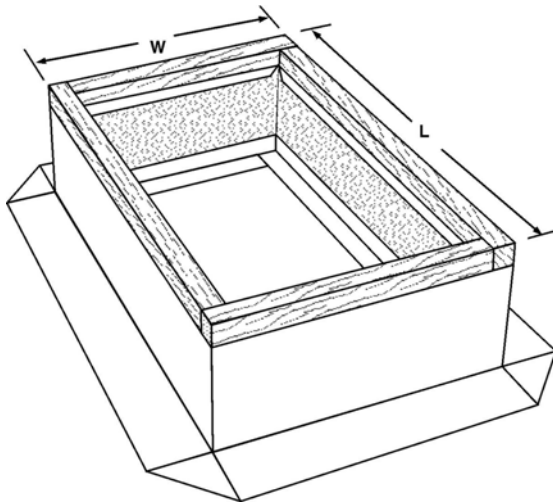

### SPECIFICATIONS AND DIMENSIONS

REFERENCE	QUAN.	MAT'L	L	W	M	H	OPTIONS