



ACME MANUFACTURING CORP.

6532 TOWER LANE, CLAREMORE, OK. 74019

ENGINEERED PRODUCTS BY CRAFTSMEN

Self-Flashing Curb Sloping Roof Single Pitch Type SFP

STANDARD FEATURES

Constructed of 18 ga. galv. steel with continuous welded seams and integral base plate for water tightness and extra strength.

Wide base flashing to insure adequate bond to roofing surface for water tight seal to roof.

Lined with 1½" fiberglass fire proof sound attenuating type insulation.

Top of curb covered with ¼" polystyrene gasket for weather seal and to reduce metal to metal conducted noise.

Custom sizes with any roof pitch.

Minimum curb height is 8" on the shortest vertical height.

OPTIONS

- Constructed of .063" aluminum.
- Interior metal liner.
- Standard heights of 12, 14, 16, 18, 20, 24", or any special height.
- 2 x 2 wood nailer secured to top ledge of curb in lieu of polystyrene gasket.
- Damper shelf – standard or custom size opening.
- Back draft damper.
- Damper motor, 120, 240, or 480 vac.
- Protective or decorative coatings.
- Heavy-gage construction.

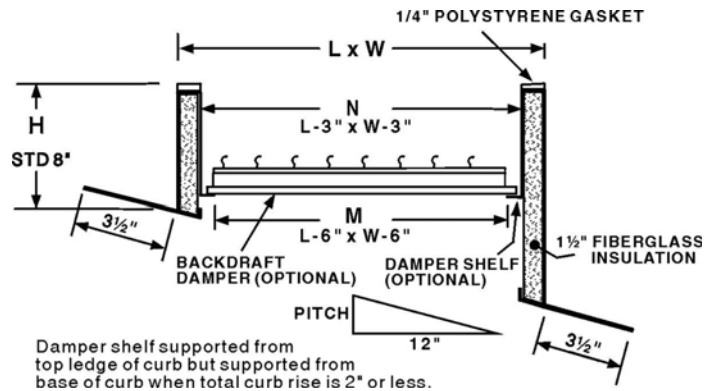
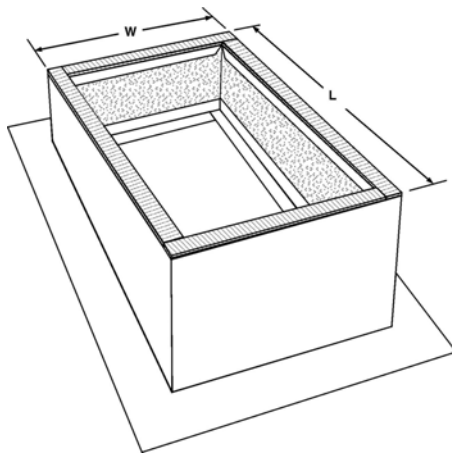

NOTE: Curb is pitched along "L" dimension

PROJECT	
LOCATION	
ARCHITECT	
ENGINEER	
CONTRACTOR	
SUBMITTED BY	
DATE	PO#

SPECIFICATIONS AND DIMENSIONS

REFERENCE	QUAN.	MAT'L	L Pitch Side	W	M	H	OPTIONS