



ACME MANUFACTURING CORP.

6532 TOWER LANE, CLAREMORE, OK. 74019

ENGINEERED PRODUCTS BY CRAFTSMEN

Curb Extension Type EC

STANDARD FEATURES

Constructed of 18 ga. Galvanized steel with continuous welded seams for water tightness and extra strength.

¼" polystyrene gasket on top ledge for weather seal and to reduce metal to metal conducted noise.

Lined with 1½" fiberglass fire proof sound attenuating thermal insulation.

Built-in back draft damper shelf and removable access panel.

OPTIONS

- Heights up to 24".
- Back draft damper.
- Motor for back draft damper, 120, 240 or 480 vac.
- Protective or decorative coatings.
- Heavy-gage construction.

PROJECT	
LOCATION	
ARCHITECT	
ENGINEER	
CONTRACTOR	
SUBMITTED BY	
DATE	PO#

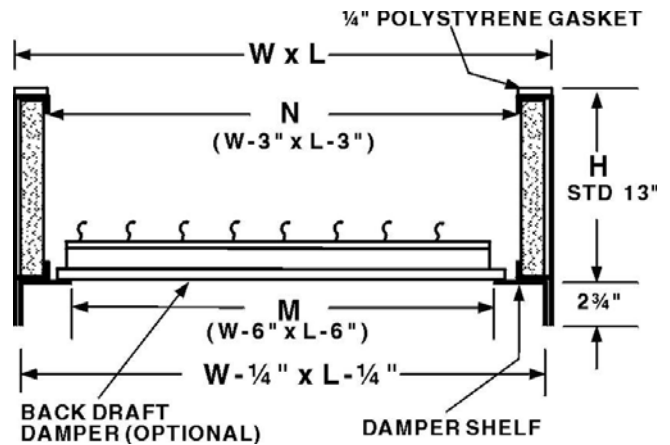
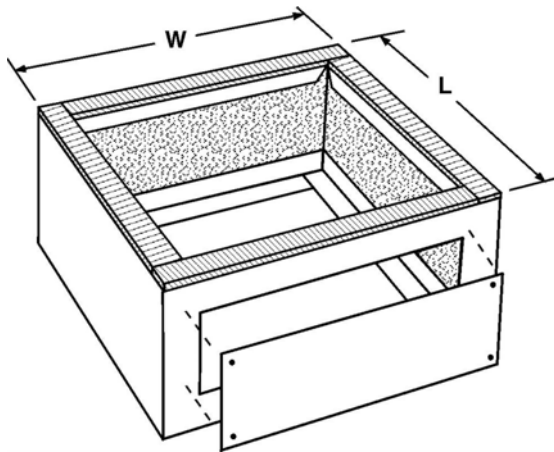

SPECIFICATIONS AND DIMENSIONS

REFERENCE	QUAN.	MAT'L	L	W	M	H	OPTIONS