



ACME MANUFACTURING CORP.

6532 TOWER LANE, CLAREMORE, OK. 74019

ENGINEERED PRODUCTS BY CRAFTSMEN

Vented Curb Extension Type ECV

STANDARD FEATURES

Constructed of 18 ga. galvanized steel with continuous welded seams for water tightness and extra strength.

¼" polystyrene gasket on top ledge for weather seal and to reduce metal to metal conducted noise.

Unit overall outside dimensions are 1" larger than the curb on which it is to be used.

4" X ¼" louver vents (4 sides).

OPTIONS

- Constructed of .063 aluminum.
- Heights up to 24".
- Protective or decorative coatings.
- Heavy-gage construction.

| | |
|--------------|-----|
| PROJECT | |
| LOCATION | |
| ARCHITECT | |
| ENGINEER | |
| CONTRACTOR | |
| SUBMITTED BY | |
| DATE | PO# |

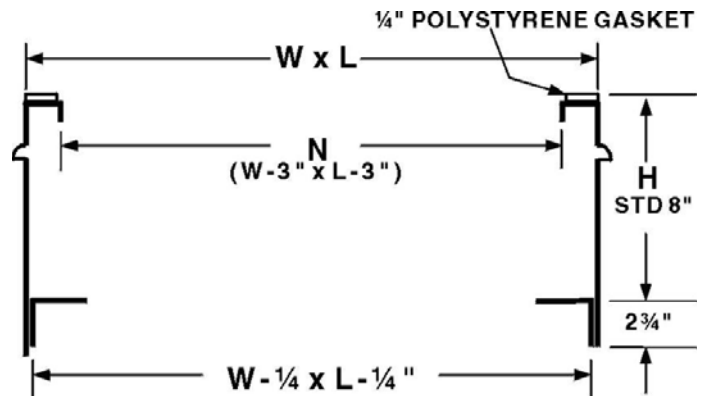
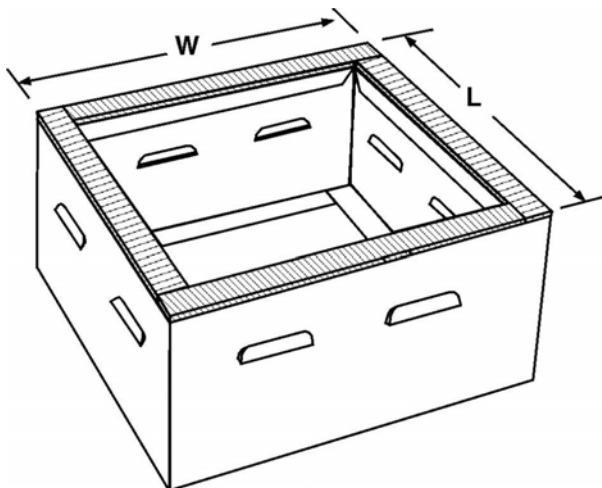

SPECIFICATIONS AND DIMENSIONS

| REFERENCE | QUAN. | MAT'L | L | W | M | H | OPTIONS |
|-----------|-------|-------|---|---|---|---|---------|
| | | | | | | | |