



**ACME MANUFACTURING CORP.**  
6532 TOWER LANE, CLAREMORE, OK. 74019

ENGINEERED PRODUCTS BY CRAFTSMEN

## Combination Curb Adapter Type CACC

### STANDARD FEATURES

Two-hole adapter for kitchen systems allows exhaust and supply fans to share common curb and roof penetration.

Constructed of 18 ga. galv. steel with continuous welded seams for water tightness and extra strength.

1/4" polystyrene gasket around top perimeter of exhaust and supply openings for weather seal.

Special sizes for any application.

### OPTIONS

- Constructed of .063" aluminum.
- 1/2" x 4" vent slots on exhaust stack
- Heavy gage construction.
- Decorative or protective coatings.

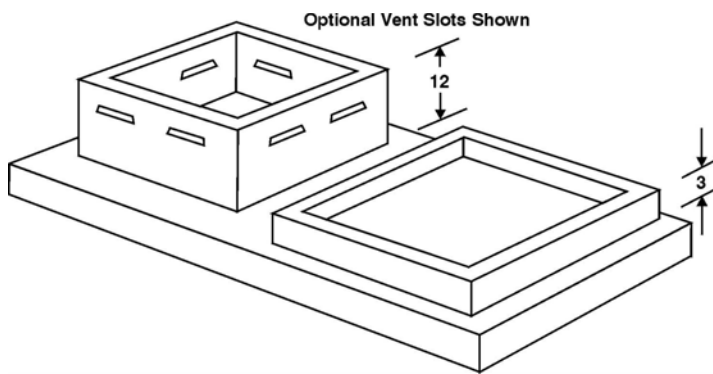

PROJECT	
LOCATION	
ARCHITECT	
ENGINEER	
CONTRACTOR	
SUBMITTED BY	
DATE	PO#

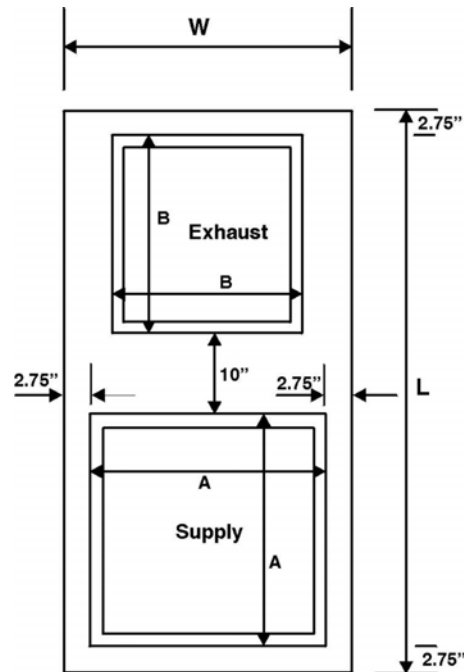

### SPECIFICATIONS AND DIMENSIONS

REFERENCE	QUAN.	A Sq. SUPPLY	B Sq. EXHAUST	W (A + 5.5)	L (A + B + 15.5)	OPTIONS