



ACME MANUFACTURING CORP.
6532 TOWER LANE, CLAREMORE, OK. 74019

ENGINEERED PRODUCTS BY CRAFTSMEN

Rooftop Equipment Curb Type RTU

STANDARD FEATURES

- Constructed of 14 ga. galv. steel.
- Internal dividers for supply, return and utility connections.
- Self-flashing design with 2" bottom flange.
- 2" x 4" treated wood nailer.
- Knockdown or factory welded construction.

OPTIONS

- Constructed of .080" aluminum or Galvalume.
- Any height.
- Pitched to match roof slope.

PROJECT	
LOCATION	
ARCHITECT	
ENGINEER	
CONTRACTOR	
SUBMITTED BY	
DATE	PO#

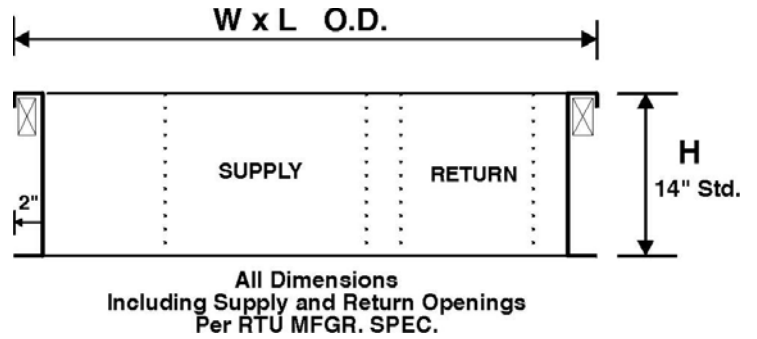
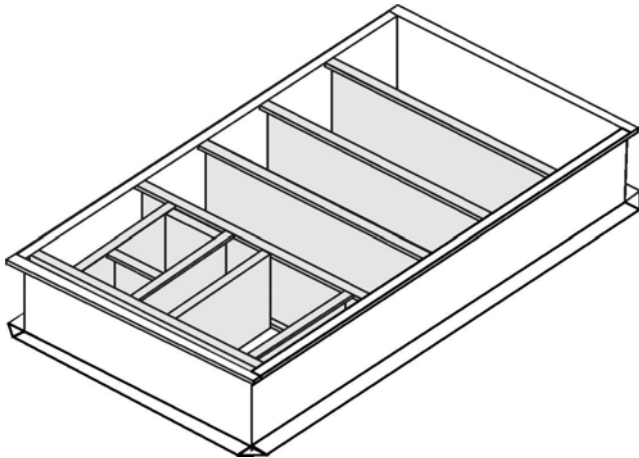

SPECIFICATIONS AND DIMENSIONS

REFERENCE	QUAN.	MAT'L	L	W	H	OPTIONS