



ACME MANUFACTURING CORP.

6532 TOWER LANE, CLAREMORE, OK. 74019

ENGINEERED PRODUCTS BY CRAFTSMEN

Metal Roof Curb With Loose Clips Type MRLC

STANDARD FEATURES

Loose "Clips" for field location of rib pockets when curb position relative to roof ribs cannot be determined prior to order. DEK-CAP™ end-cap flashing supplied for standing-seam roof panels. Factory welded clips supplied for R-panel roofs.

Constructed of 18 ga. galv. steel with continuous welded seams and integral base plate for water tightness and extra strength.

3½" wide base flashing on sides to cover roof panel.

Upper flashing is 8" wide with cricket style water diverter welded to base.

Lined with 1½" fiberglass fire proof sound attenuating thermal insulation.

Top ledge covered with ¼" polystyrene gasket for weather seal and to reduce metal to metal conducted noise.

Minimum curb height is 8" on the shortest vertical height.

OPTIONS

- Constructed of 18 ga. galvalume steel or .063 aluminum.
- Interior metal liner.
- 1½" wood nailer secured to top ledge of curb in lieu of gasket.
- Standard heights of 12, 14, 16, 18, 20, 24", or any special height.
- Damper shelf – standard or custom size opening.
- Back draft damper; Damper motor, 120, 240, or 480 vac.
- Security bars.
- Protective or decorative coatings.

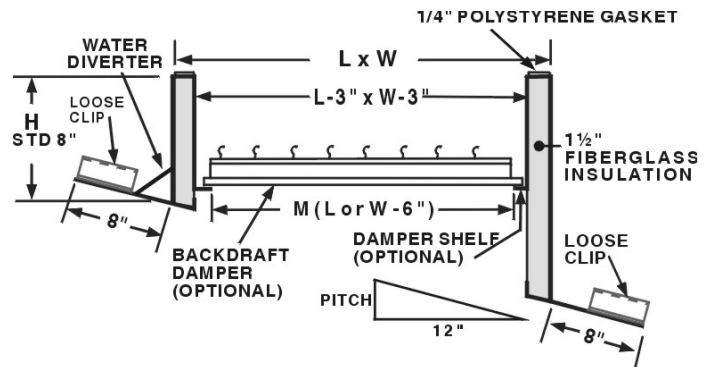
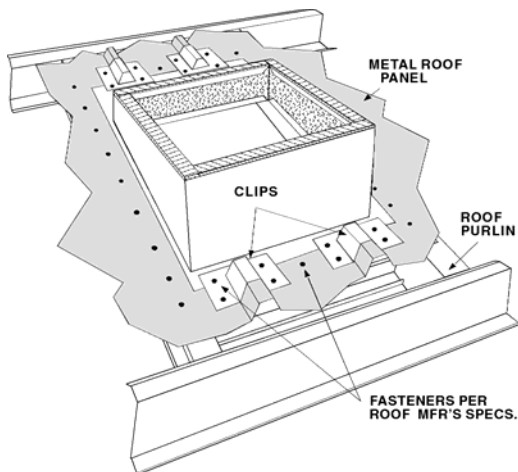

Damper shelf supported from top ledge of curb, but supported from base of curb when total rise over length > 2".

PROJECT	
LOCATION	
ARCHITECT	
ENGINEER	
CONTRACTOR	
SUBMITTED BY	
DATE	PO#

SPECIFICATIONS AND DIMENSIONS

REFERENCE	QUAN.	L (Pitch Side)	W	H	PITCH	OPTIONS