



**ACME MANUFACTURING CORP.**

6532 TOWER LANE, CLAREMORE, OK. 74019

ENGINEERED PRODUCTS BY CRAFTSMEN

## Roof-Over-Flashing Curb With Raised Cant Base Custom Sized Type RFCRC

### STANDARD FEATURES

Constructed of 18 ga. galv. steel with continuous welded seams and integral base plate for water tightness and extra strength.

Utilizes a raised cant to accommodate roofs having extra insulation above the roof deck. Standard rise is 1½" with a maximum rise of 4".

Large 3" built-in 45° raised cant to accommodate roofing to top of curb. Welded corners have mitered cants for better lay of roofing materials at corners.

Lined with 1½" fiberglass sound attenuating thermal insulation.

2 x 2 wood nailer secured to top ledge of curb.

Custom sizes to meet any dimensional requirements or roof opening.

PROJECT	
LOCATION	
ARCHITECT	
ENGINEER	
CONTRACTOR	
SUBMITTED BY	
DATE	PO#

### OPTIONS

- Constructed of .063" aluminum.
- Interior metal liner.
- Standard heights of 12, 14, 16, 18, 20, 24", or any special height.
- Raised cant up to 4".
- Damper shelf – standard or custom size opening.
- Back draft damper.
- Damper motor, 120, 240, or 480 vac.
- Protective or decorative coatings.
- Treated wood nailer.
- Heavy-gage construction.

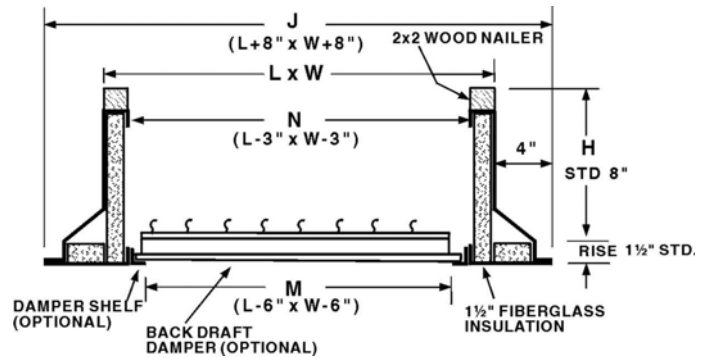
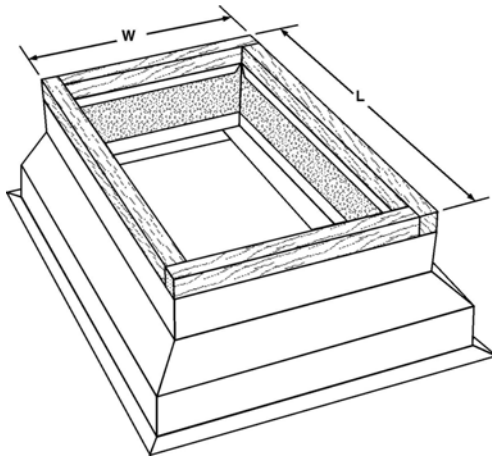

### SPECIFICATIONS AND DIMENSIONS

REFERENCE	QUAN.	MAT'L	L	W	M	H	OPTIONS