



ACME MANUFACTURING CORP.

6532 TOWER LANE, CLAREMORE, OK. 74019

ENGINEERED PRODUCTS BY CRAFTSMEN

Trimline™ Intake Vent Type TIV

STANDARD FEATURES

Free area at perimeter equals 200% of throat area for low velocity intake.

Hood constructed of .050" aluminum. Base constructed of .080" aluminum.

Hood reinforced and braced for extra strength with wide overhang for storm protection.

Hood assembled with standing and snap back seams secured with spot welds.

All curb cap corners miter cut and continuous welded.

Bird screen of 1/2" x 1/2" mesh galvanized welded wire.

OPTIONS

- Hinged hood.
- Anti-condensate coating.
- 1" fiberglass insulation.
- Aluminum bird screen
- Aluminum insect screen.
- Aluminum mesh cleanable filters, 1" or 2" thick.
- 100 MPH construction.
- Snow screen: bird screen plus insect screen.
- Protective or decorative coatings.

PROJECT	
LOCATION	
ARCHITECT	
ENGINEER	
CONTRACTOR	
SUBMITTED BY	
DATE	PO#

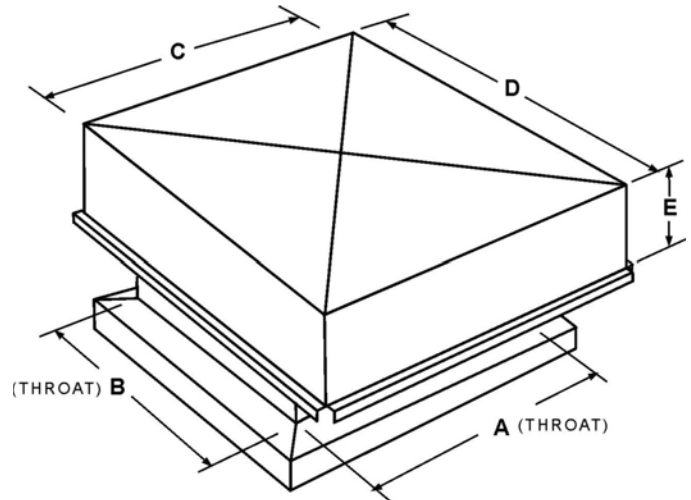
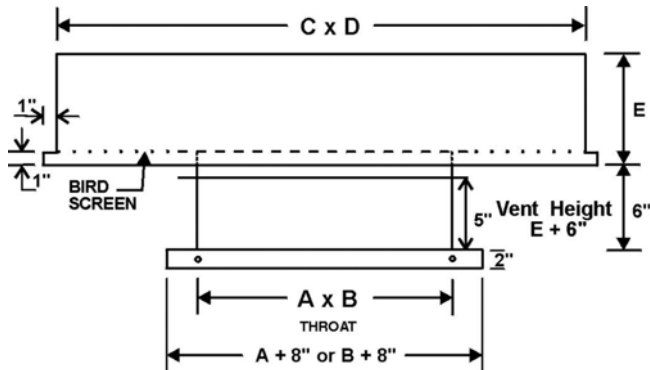

SPECIFICATIONS AND DIMENSIONS

REFERENCE	QUAN.	Throat Width A	Throat Length B	Hood Width C	Hood Length D	Hood Height E	OPTIONS